

AMPS™ – AUTOMATIC MECHANICAL PACKING SYSTEM

Installation, Operation and Rebuild Instructions

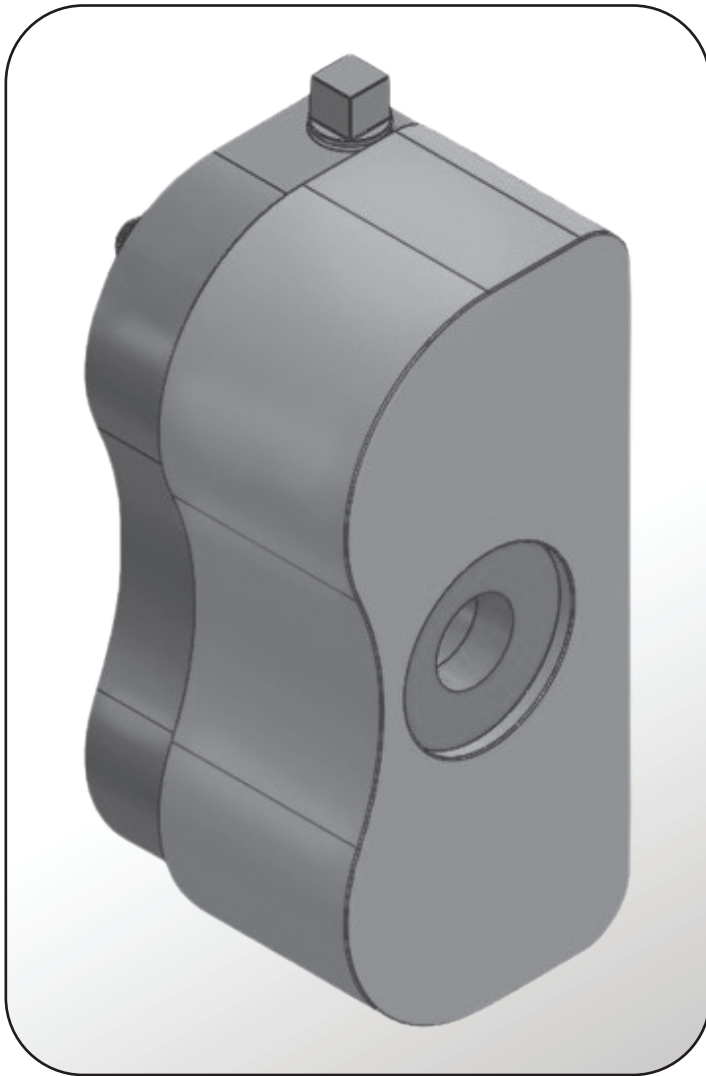

TABLE OF CONTENTS:		Page
1.0	Cautions	2
2.0	Transport and Storage	2
3.0	Description	2
3.1	Parts/Kit Identification	
3.2	Operating Parameters	
3.3	Intended Use	
4.0	Preparation for Installation	3
4.1	AMPS™	
4.2	Energizing Medium	
4.3	Equipment	
5.0	AMPS™ Installation	3-4
6.0	Commissioning/ Equipment Start-up	5
7.0	Decommissioning/Equipment Shut Down	5
8.0	Spare Parts	5
9.0	AMPS™ Rebuild	5-6
9.1	AMPS™ Disassembly	
9.2	AMPS™ Assembly	
10.0	Returns	6
	Appendix	7-9

AMPS™ Data Reference

(from Box Label)

ITEM#: _____

ITEM DESC: _____

(Example: AMPS™ KIT 2X ACTUATOR – 2.000 BORE-1/2 BOLT-.750 TRAVEL)

INSTALLATION DATE _____

AMPS™ INSTALL PRESSURE (SECTION 5.0) _____

AMPS™ FINAL PRESSURE (SECTION 6.0) _____

Equipment Data Reference

(See section 4.3)

AVAILABLE PRESURE _____

S.B. / FLUSH PRESSURE _____

SHAFT / SLEEVE DIA. _____

PACKING CROSS-SECTION _____

QTY / DIA. OF BOLTS _____

1.0 CAUTIONS

These instructions are general in nature. It is assumed that the installer is familiar with AMPST[™] and with the requirements of their plant for the successful use of mechanical packing. If in doubt, seek assistance from someone in the plant who is familiar with AMPST[™] or delay the installation until a mechanical packing representative is available. All necessary auxiliary arrangements for successful operation (energizing media, piping connections) as well as safety devices must be employed. These decisions are to be made by the user.

The decision to use this technology or any other Chesterton[®] technology in a particular service is the customer's responsibility. Ensure that all the AMPST[™] component materials are compatible with the process fluid and below the maximum temperature and pressure limits as provided in Section 3.2. This will prevent possible personal injury.

2.0 TRANSPORT AND STORAGE

Transport and store AMPST[™] in their original packaging. AMPST[™] components may be subject to alteration and ageing. It is therefore important to observe the following conditions for storage:

- Dust free environment
- Moderately ventilated at room temperature
- Avoid exposure to direct sunlight and heat
- For elastomer seals, storage conditions according to ISO 2230 should be observed.

3.0 DESCRIPTION

3.1 Parts/ Kit Identification (See Appendix A)

AMPST[™] KIT

- AMPST[™] Actuators
- Pressure regulator with gauge – 3/8 NPTF
- Check valve – 3/8 NPT
- Booster Regulator – Supplied if needed

ACCESSORY KIT

- Interconnecting hoses
- Interconnecting hose fittings
- Pipe Plug
- PTFE Tape

SPARE PARTS KIT

- Seals – 2 each
- Grease

3.2 Operating Parameters

Maximum Pressure Limits:

AMPST[™] System: 300 psi (20.6 bar)

Temperature Limits:

- AMPST[™] Actuators: 400°F (204°C)
- AMPST[™] Regulator: 175°F (80°C)
- AMPST[™] Check Valve: 350°F (176°C)
- Interconnecting Hosing: 275°F (135°C)

Other Requirements:

- Pressure regulator provided with the AMPST[™] kit must have self-relieving function.
- Do not insulate AMPST[™] actuators.

Standard Materials: (See Appendix A for exploded view)

- Metallic Components (Housing, Top Plate, Shafts): 316SS
- Metallic Hardware (Screws): 18-8SS or 316SS
- Cover: Thermoplastic Polyurethane (TPU)
- Seal: Fluorocarbon-based elastomer (FKM)
- Fittings: 304SS or 316SS
- Hosing: 303SS PTFE braided with blended rubber cover
- Grease: Silicone oil-based compound
- Thread Locker: General purpose / medium strength

Customer to ensure compatibility of materials with the equipment medium before installing in service

3.3 Intended Use

The AMPST[™] and packing are to be operated within the operating parameters as specified. For use beyond the intended application and/or outside the operating parameters, consult Chesterton[®] Mechanical Packing Application Engineering to confirm the suitability of the AMPST[™] prior to installing in service.

4.0 PREPARATION FOR INSTALLATION

4.1 AMPS™

1. Review packaging to ensure no damage has occurred to the contents.
 - i. Note: Limiting screw and shaft screws shall not be tampered with prior to installation.
2. On the AMPS™ data reference on Page 1, record the kit item numbers and names found on the box label.
3. Read Section 5.0 AMPS™ Installation completely before installing.

4.2 Energizing Medium

1. Identify energizing medium source that will be used to pressurize the AMPS™ actuators (i.e.: plant air or bottled inert gas).
 - i. Note: The maximum allowable pressure supplied to the regulator shall not exceed 300 psi (20.6 bar) per the regulator manufacturer.
 - ii. Energizing supply must be constant without interruption to the AMPS™ actuators. If supply is lost, the AMPS™ check valve will hold pressure for a duration of time. It is recommended to install a pressure monitoring alarm device to advise when the supply is lost as a precaution.
2. Energizing medium shall contain particulate no greater than 3 microns and shall be dry and moisture free. Install a filter and separator if required.

4.3 Equipment

1. Ensure the following parameters are as provided at the time the AMPS™ was designed. Reference the survey form or proposal drawing and record on the Equipment Data Reference block on page 1. If any of the parameters listed below differ, contact Mechanical Packing Application Engineering before installing product.
 - i. Available supply pressure
 - ii. Stuffing box / flush pressure
 - iii. Shaft diameter
 - iv. Packing cross-section
 - v. Bolt / stud diameter and quantity

5.0 AMPS™ – INSTALLATION

Precaution: Follow all plant procedures and equipment manufacturer safety practices throughout the installation.

Limiting screw and shaft screws shall not be tampered with prior to installation.

1. See Appendix B for standard P&ID diagram of AMPS™ system.
2. Install the check valve to the inlet of the AMPS™ regulator with thread sealant (tape or paste).
3. Install interconnecting fittings (See Appendix C).
4. Remove old packing from stuffing box. Stuffing box should be free of any old packing residue, solids, and corrosion left from the process.
5. Inspect the equipment shaft/sleeve. The shaft/sleeve should be in good condition and free of excessive wear, corrosion or pitting for optimum packing service life.
6. Clean the packing gland and gland follower. Remove burrs, corrosion or any residual material which would impede insertion into the stuffing box.
7. Pack the stuffing box according to the specific Chesterton® packing installation procedure (Visit www.Chesterton.com).

5.0 AMPST™ - INSTALLATION CONT.

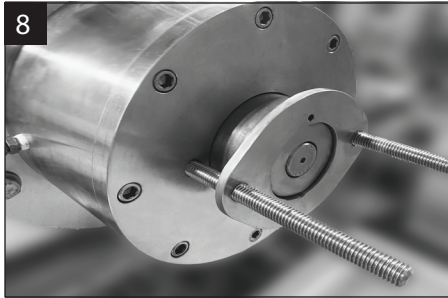

Install packing gland and gland flange such that the gland pilots into the stuffing box and sits evenly against the packing set.

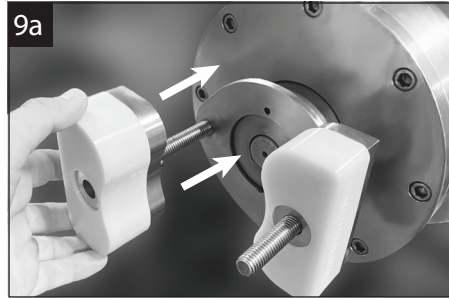

Install the actuator assemblies onto the studs/bolt and on top of the packing gland. Installation will vary depending on the equipment clearances and design. For applications with ample axial clearance, install AMPST™ over the stud as shown in 9a.

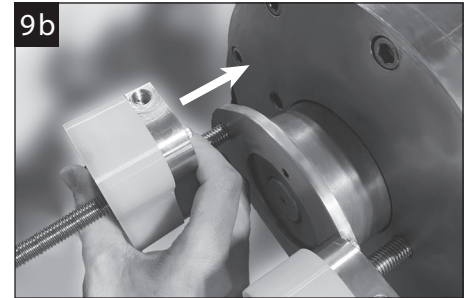

For applications with minimal axial clearance, the stud may be removed to install the AMPST™ actuator. With the stud removed and the AMPST™ installed on the stud, re-install the stud to the equipment.

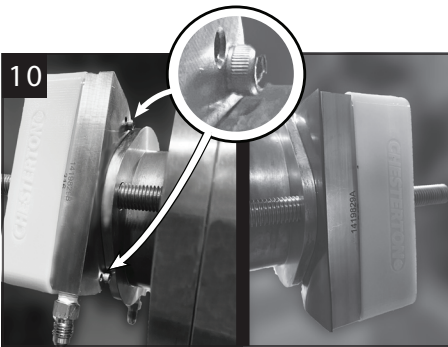

Ensure the AMPST™ devices are not in contact with the shaft by utilizing the anti-rotation screws installed on the bottom of the AMPST™ device. Remove the anti-rotation screws if they interfere with the gland and install the FKM gasket supplied with the AMPST™ kit underneath the actuator to prevent rotation.

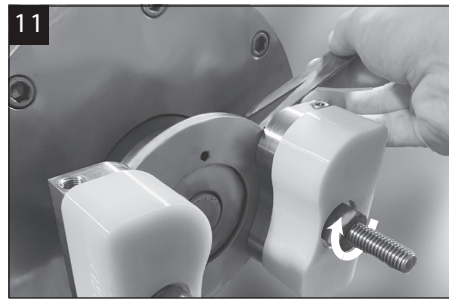

Finger tighten nuts/bolts until the AMPST™ is in contact and seated on top of the packing gland. Take-up gland nuts/bolts finger tight, verifying gland and packing gland flange are perpendicular and square to the shaft.

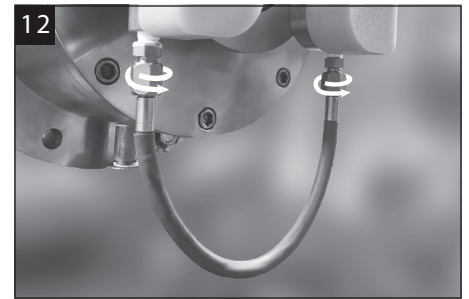

Install the interconnecting hose between the actuators to the installed fittings (See Appendix C). Use a feeler gauge to make sure that the gland is not touching the shaft (gland/shaft contact will generate excess heat and cause equipment wear and/or damage).



Energizing supply to the regulator shall be closed or disconnected. Ensure the regulator is set to zero (0) psi (counter-clockwise) and connect the regulator to the actuator inlet with the customer supplied hosing.

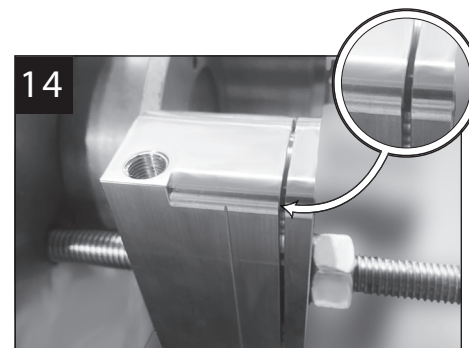

Remove all yellow covers from the AMPST™ actuators and turn on energizing supply to the regulator. Increase pressure in the regulator in (2-3) psi increments every minute until initial separation of the AMPST™ actuator occurs. Once separation occurs between the two mated surfaces, record the regulator inlet pressure on page 1 as the AMPST™ install pressure. While AMPST™ actuators are pressurized, bubble test all fittings for leaks.

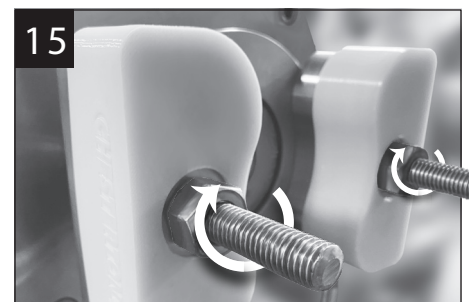

Reinstall the yellow AMPST™ covers.

6.0 COMMISSIONING / EQUIPMENT START-UP

1. Increase AMPS™ pressure regulator to the value recorded during the installation.
2. Start the equipment per normal plant procedure – shaft rotation.
3. At startup, observe leakage. Note that the pressure and time increments below are provided as a general rate. The pressure and time increments may be adjusted to accommodate the application and Chesterton® style packing utilized.
 - i. If leakage is heavy, increase the pressure regulator in approximately 5 psi (or equivalent units) increments, waiting 3-5 minutes between each increase.
 - ii. Once leakage starts to decrease, increase time between adjustments to 5-15 minutes and pressure increments to 1-3psi until acceptable controllable leakage is achieved.
4. As the leakage rate decreases, the time between adjustments should be increased (typically 15 minutes). Continue to adjust in 1-5 psi increments as needed.
5. If the leakage rate decreases below the desired rate during this period, decrease pressure regulator in 1-5 psi increments until desired rate is achieved.
6. For reference, record the final set regulator pressure on page 1.
7. If the pressure or speed of the equipment changes, check leakage rate and adjust, as necessary.
8. If AMPS™ reaches maximum travel as indicated by the 80% travel mark on the back of the housing, remove the cover and tighten the gland nut/bolt located above each AMPS™ actuator in a star or criss-cross shaped bolting pattern until each AMPS™ actuator is nearly fully closed. Leave a visible gap between the AMPS™ housing and top plate as shown in Section 5.0, Step14
 - i. When tightening the gland nuts/bolt, the regulator will vent the increased pressure in the AMPS™ actuator and thus maintain a constant load per the regulator setting.
 - ii. Reinstall yellow cover.
 - iii. Proceed to adjust regulator per steps 4 and 5 as necessary.

7.0 DECOMMISSIONING / EQUIPMENT SHUT DOWN FOR REPACK OR AMPS™ REBUILD

Shutdown and secure equipment per existing plant procedures. Ensure that the equipment is electrically isolated. If the equipment has been used on toxic or hazardous fluids, ensure that the equipment is correctly decontaminated and made safe prior to commencing work. Ensure the equipment is isolated. Check that the stuffing box is drained from any fluid and pressure of equipment is fully released.

If repack is required, fully open AMPS™ regulator by turning T-handle counter-clockwise; the pressure regulator gauge shall read zero psi. Remove AMPS™ actuators one by one from the gland and remove hoses if necessary. Fittings shall remain installed on the AMPS™ actuators. In case of disposal, ensure the local regulations and requirements are followed.

8.0 SPARE PARTS

Use only Chesterton® original spareparts. Use of non-original spare parts represents risk of failure, danger to persons/equipment and voids any applicable warranty.

Spare Part Kits can be purchased from Chesterton®, referencing the (as manufactured) AMPS™ data from the recorded information on the cover page of these instructions.

9.0 AMPS™ - REBUILD

A correctly installed and operated AMPS™ actuator requires little maintenance. Some components of an AMPS™ actuator such as seal rings may require replacement over time. While an AMPS™ is installed and operating, maintenance is not possible.

The equipment must be fully decommissioned as described in section 7.0 and AMPS™ actuator removed. Note, it is recommended that an AMPS™ spare part kit be held in stock to allow quick repair.

9.0 AMPS™ - REBUILD CONT.

9.1 AMPS™ Disassembly



Remove the yellow cover.

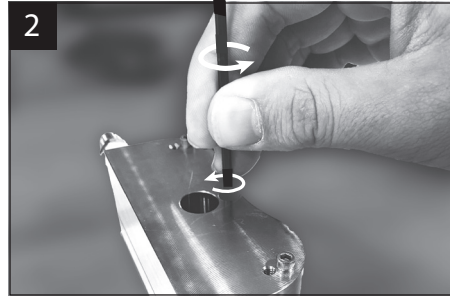

Locate the limiting screw on the bottom of the AMPS™ housing centered with the stud clearance hole. Remove the limiting socket head screw and store in an area as to not get lost. Locate the limiting screw on the bottom of the AMPS™ housing centered with the stud clearance hole. Remove the limiting socket head screw and store in an area as to not get lost.



Separate the AMPS™ top plate from the housing until the shafts and seals are fully separated and removed from the housing. Shafts shall remain installed to the top plate as shown in the figure below.



Remove the two shaft seals using a non-metallic tool to ensure there is no damage to the sealing surface on the shafts. Inspect shafts and housing bores for defects.



Clean the AMPS™ actuator with a clean cloth and ensure there is no remaining grease, moisture or debris.



Regrease entire surface of the AMPS™ housing bores with the grease provided in the spare parts kit.

9.2 AMPS™ Assembly



Per procedures of specific seal used, grease and install the new shaft seals provided in the spare parts kit to the shaft grooves. Ensure seal is properly seated and is not twisted.

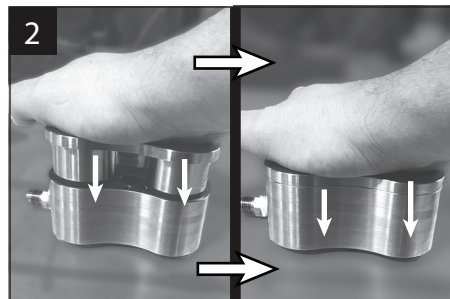

Carefully align the two shafts with the housing bores and press the top plate by hand until shaft seals are seated into the housing. Close AMPS™ actuator to fully closed position.

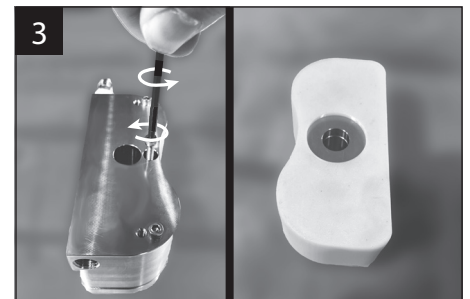

Ensure limiting screw threads are clean and undamaged. Apply thread locker* and hand tighten limiting screw until screw is fully set and can't be tightened any further. Do not overtighten screw as to not strip the threads. Reinstall cover.*Contact Chesterton® Applications Engineering for suggestions.

10.0 AMPS™ - RETURNS AND HAZARD COMMUNICATION REQUIREMENTS

AMPS™ components returned to Chesterton® that have been in operation must comply with Chesterton®'s hazard communication requirements. Please coordinate any returns with Chesterton® - "After Sales Department" to ensure proper procedures are followed.

APPENDIX A



AMPS™ KIT

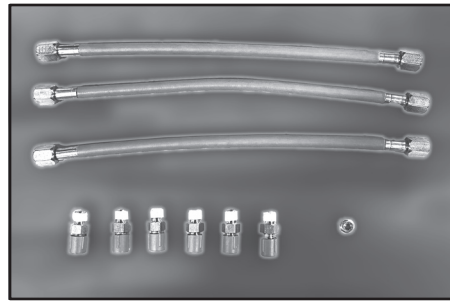

**ACCESSORY KIT
(PTFE TAPE NOT SHOWN)**

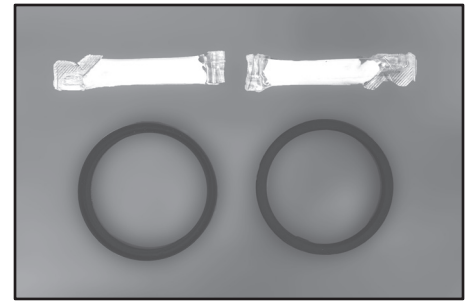

SPARE PART KIT

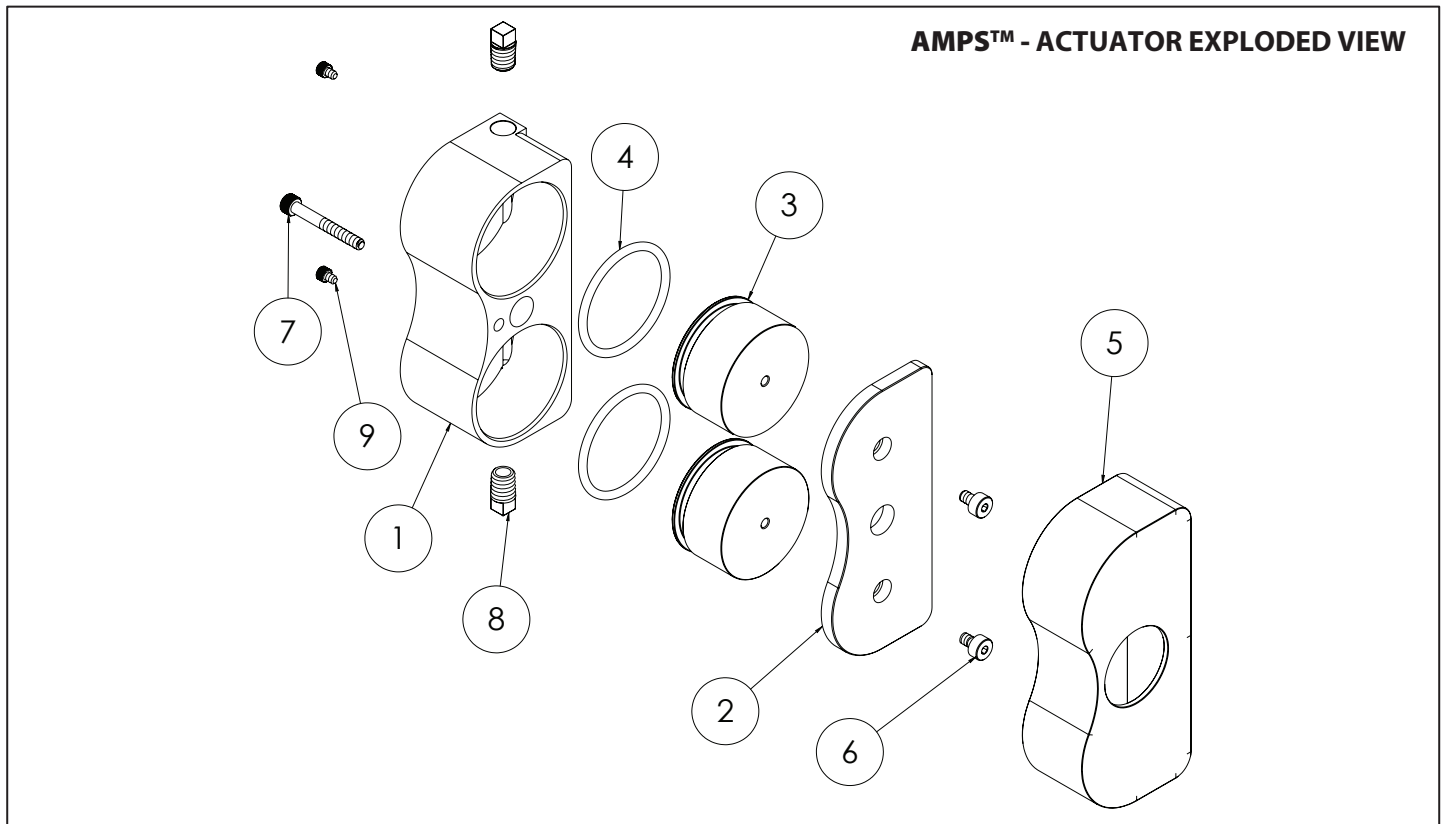

ITEM NO.	DESCRIPTION	QTY
1	HOUSING	1
2	TOP PLATE	1
3	SHAFT	2
4	SEAL	2
5	COVER	1
6	SHAFT SCREW	2
7	LIMITING SCREW	1
8	PLASTIC PLUG	2
9	ANTI -ROTATION SCREWS	2

Standard PI&D Diagram For AMPS™ Application

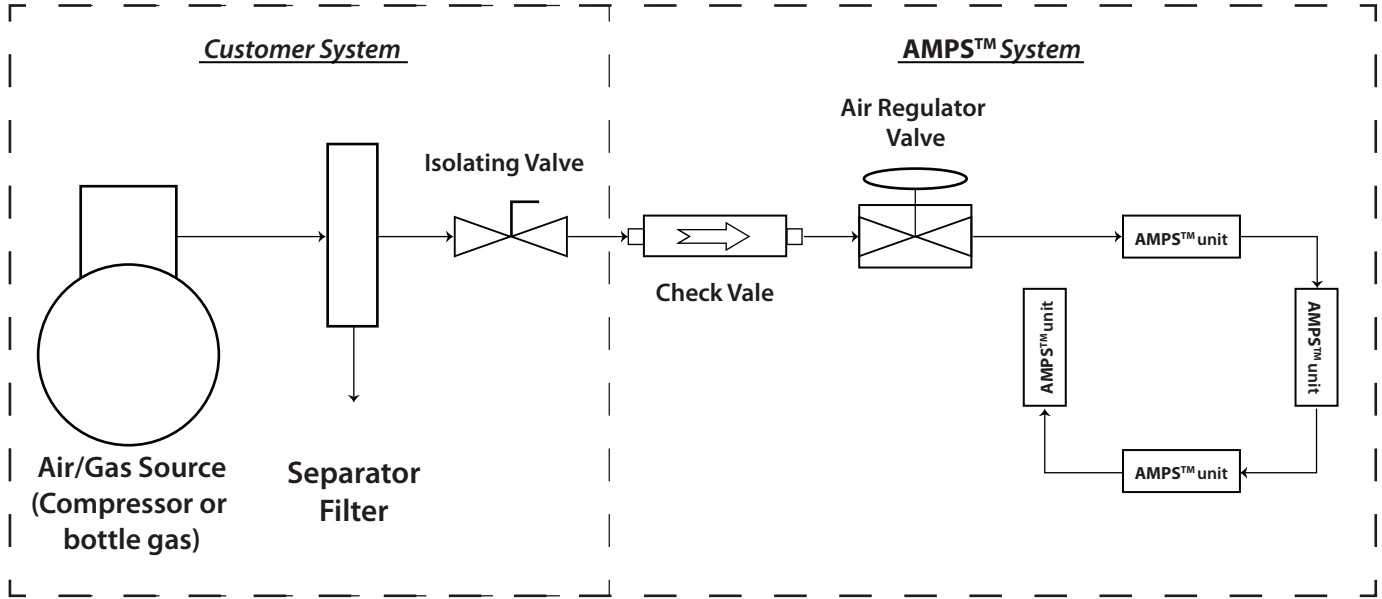

1. Ensure all pipes , fittings, and equipment are sufficiently rated.
2. Check valve function - backflow prevention.
3. Max rating for Chesterton® provided regulator is 300psi. Regulator must have self-relieving function.
4. Air source greater than 300psi must be regulated down.
5. AMPS™ setup shown in this diagram is typical for a four bolts gland.
6. Air/ Gas source must be inert.

APPENDIX C

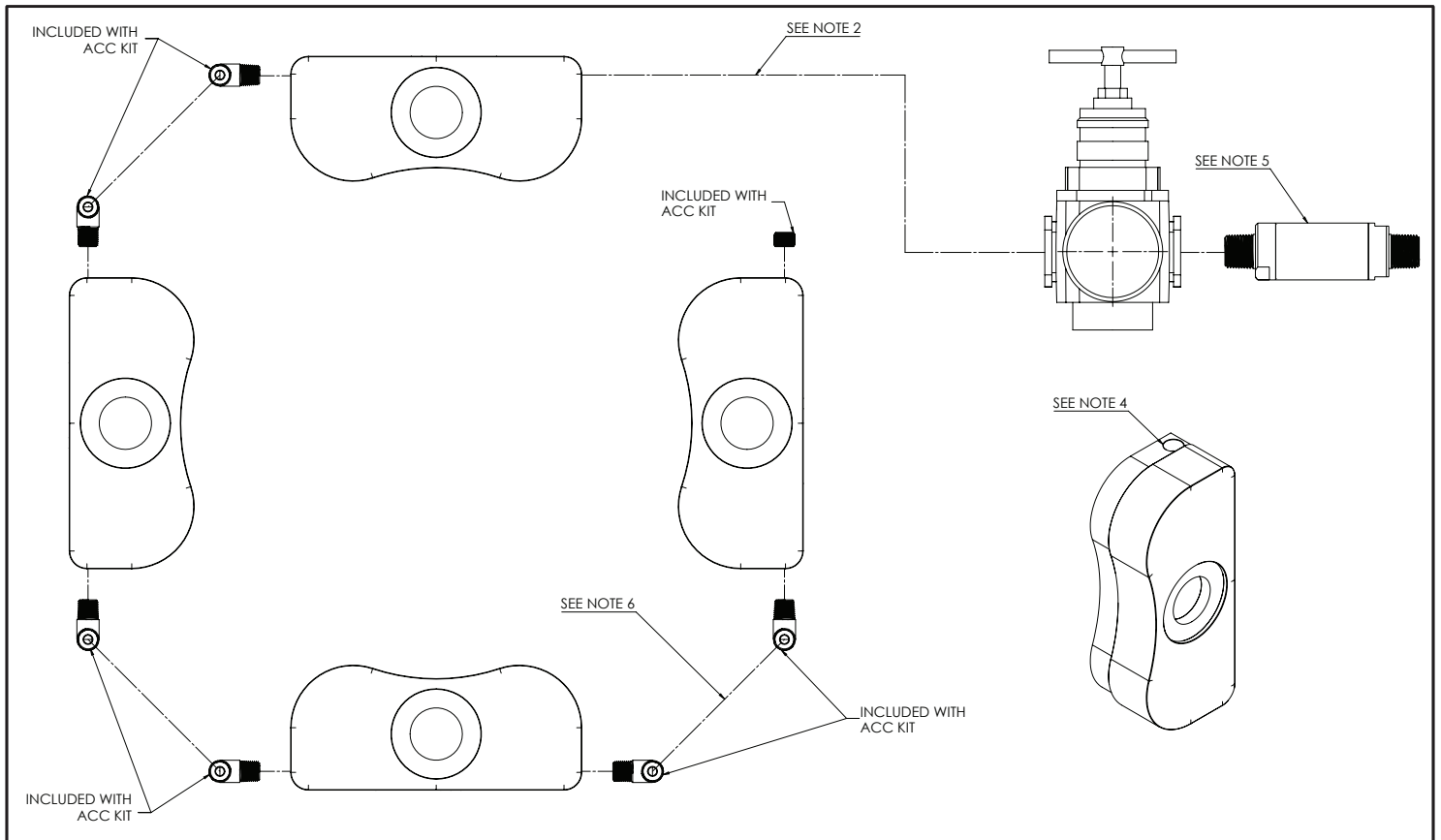

NOTES:

1. AMPS™ accessory kit includes the interconnecting fittings, hoses, pipe plug and PTFE tape necessary to connect the AMPS™ actuators together.
 - i. Fittings shape (straight or elbow) and hosing length is designed per application.
 - ii. PTFE tape is only required for the 1/8NPT ends installing into the AMPS™ actuator.
 - iii. Hoses connect to the fittings with JIC flared connections. Wrench tighten with no PTFE tape to achieve acceptable seal.
2. Fittings and hose to connect the regulator to the AMPS™ actuator are not supplied with the Accessory kit and are the responsibility of the customer.
3. Customer supplied fittings and hosing may be used if accessory kit is not supplied. Ensure the hoses and fittings are rated to the maximum pressure rating of the AMPS™ actuator.
4. The AMPS™ actuators are designed with 2ea 1/8 NPTF. The regulator has 2ea 3/8NPTF.
5. Check valve to be installed to the inlet of the regulator.
6. Hoses in the diagram are not shown and are indicated as a dashed line.
7. Diagram is representative of a four-bolt pattern and to be used as reference. The same logic can be used on other bolting patterns.



860 Salem Street
Groveland, Massachusetts 01834 USA
Telefono: 781-438-7000 • Fax: 978-469-6528
www.Chesterton.com

© A.W.Chesterton Company, 2024. All rights reserved. ® Registered trademark owned and licensed by the A.W.Chesterton® Company in USA and other countries. AMPS™ is a trademark of A.W. Chesterton Company.